

Air heater EUEG

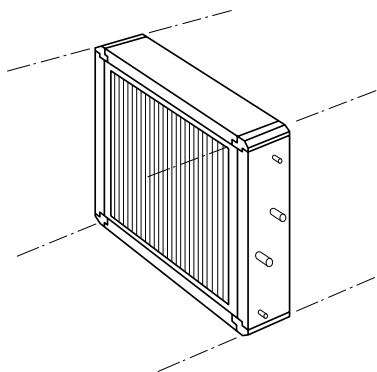

Air heater for hot water EUEG

The finned heat exchanger is intended for use as a pre-heater for preventing frost from forming on filter at moderate winter temperatures, i.e. down to -7°C.

Finned heat exchanger consisting of copper tubes and with or without profiled fins of aluminium or copper.

All heat exchangers are equipped with plugged connections for venting and drainage.

Material.

Tubes	Fin	Headers	
		Connection size	
Copper	Aluminium	25	Copper
		32-50	Steel, painted
Copper	Copper	25-50	Copper
Copper	Tinned copper	25	Copper
		32-50	Steel, painted
Copper	Corropaint painted aluminium	25	Copper
		32-50	Steel, painted

The casing around the finned coil is available in galvanized or stainless sheet steel.

Max. working pressure 16 bar
 Max. water temperature 150 °C